



0900 SERIES

125LBS



FEATURES

KINGPIN: 7/16" rivet
RACEWAY: 7/32" diameter upper and lower race; hardened steel load bearings
BUSHING: Nylon or steel
AXLE&NUT: 1/4" axle and lock nut
FINISH: Corrosion resistant bright zinc finish

HARDENED: Yoke and washers
SPECIAL: Most stems available for swivel and rigid casters. Upper and lower diameter race is equal for added performance and strength
LEG SPACING: 1"

EXCELLENT FOR:

- Institutional furniture
- Hospitals
- Food service equipment
- Tool boxes
- Store fixtures



OPTIONS:

- TLB Top Locking Brake (swivel only)
- SLB Side Locking Brake (SLB will not work with PB or TG)
- AR Riveted Axle
- CD Cross Drilled holes
- TG Thread Guards

WHEEL		CASTER				PART NUMBER				
Diameter	Tread Width	Capacity Lbs.	Bearing Type	Swivel Radius	Overall Height	Wheel Type	Swivel	Caster Weight (lbs)	Rigid	Caster Weight (lbs)
3"	7/8"	75	Precision			ProTech™ Black Crown - PB	S0933-***-PROBL-PB-TG	0.95	R0933-***-PROBL-PB-TG	0.78
		75	Plain			ProTech™ Flat	S0933-***-PROF	0.88	R0933-***-PROF	0.71
		100	Steel			Conductive Soft Rubber	S0933-***-CSR	1.02	R0933-***-CSR	0.85
		100	Precision			ICE™	S0933-***-ICE-PB	1.00	R0933-***-ICE-PB	0.83
		100	Steel	2 3/8"	3 7/8"	Soft Rubber	S0933-***-SR	1.02	R0933-***-SR	0.85
		100	Steel			Soft Rubber Grey	S0933-***-SRG	1.02	R0933-***-SRG	0.85
		125	Plain			Polyolefin	S0933-***-PO	0.88	R0933-***-PO	0.72
		125	Nylon			Envirothane™	S0933-***-U	0.94	R0933-***-U	0.77
		125	Nylon			Envirothane™ Grey	S0933-***-UG	0.94	R0933-***-UG	0.77

* Caster weight and OH based on Plate

* See stem options for overall height (OH) differences

FINISHES:

- 093AB Antique Brass
 - 093AC Antique Copper
 - 0934F Black Flat
 - 0934G Black Gloss
 - 0934I Black Ionic
 - 0931 Brass Lacquer
 - 093BN Brush Nickel
 - 0932 Chrome
 - 0935 Yellow Chromate
- Inquiries on other finishes welcome

ICE WHEEL COLOURS

+Actual colours may vary

COLOUR	PART NUMBER	SIZE AVAILABILITY	
CLEAR	ICE	2" * 2 5/16" * 3"	
BLUE	ICEB	2" * 2 5/16" * 3"	
BLACK	ICEBL	2"	
GREEN*	ICEG*	2" * 2 5/16" * 3"	
ORANGE*	ICEO*	3"*	
PURPLE*	ICEP*	3"*	
PINK	ICEPI	3"	
RED*	ICER*	2" * 2 5/16" * 3"	

* Custom order run 2,500 pieces minimum. Call for availability



PLATE DIAGRAMS

STANDARD PLATE: A28D

Plate Thickness: 3/32"



Threaded Stem HW



Threaded Stem HN

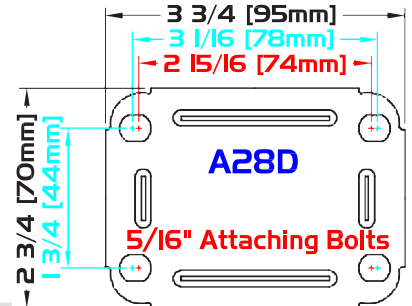

THREADED STEMS HEX WASHER

-.0937" [2.38mm] To Std OH

***	DIAMETER	LENGTH	TYPE
3/8-16X1HW	3/8"	1"	NC
1/2-13X1HW	1/2"	1"	NC
1/2-13X1 1/2HW	1/2"	1 1/2"	NC
1/2-13X2 1/4HW	1/2"	2 1/4"	NC

THREADED STEMS HEX NUT

+.1562" [3.97mm] To Std OH

***	DIAMETER	LENGTH	TYPE
1/2-13X1HN	1/2"	1"	NC
1/2-13X1 7/8HN	1/2"	1 7/8"	NC
1/2-13X3 1/2HN	1/2"	3 1/2"	NC

ROUND STEMS

-.0937" [2.38mm] To Std OH

***	DIAMETER	LENGTH	TYPE
437X1 7/8	7/16"	1 7/8"	Plain
437SX1	7/16"	1"	Friction Ring
437SX1 5/16	7/16"	1 5/16"	Friction Ring
437SX1 7/8	7/16"	1 7/8"	Friction Ring
625S	5/8"	1 5/8"	Friction Ring
812S	13/16"	2"	Friction Ring
862S	.862"	2"	Friction Ring
875S	7/8"	2"	Friction Ring
995S	.995"	2 1/2"	Friction Ring
1.050S	1 3/64"	2 1/2"	Friction Ring

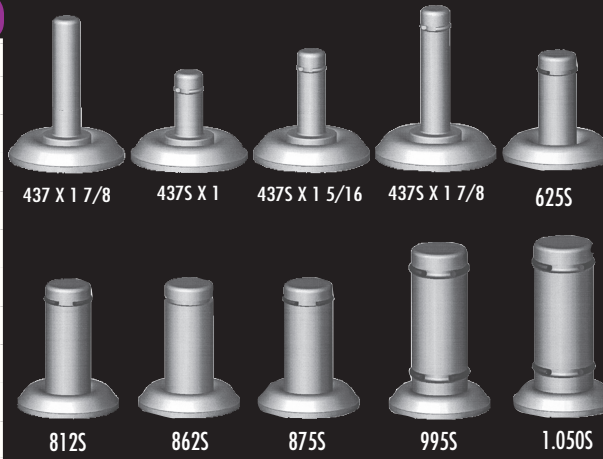

* Tapped holes upon request.

** Special CD hole locations upon request.

*** Friction rings not applied with cross drill

SQUARE STEMS

-.0937" [2.38mm] To Std OH

***	DIAMETER	LENGTH
3/4SQ	3/4"	2"
7/8SQ	7/8"	2"

* Tapped holes upon request.

** Special CD hole locations upon request.

*** Friction rings not applied with cross drill

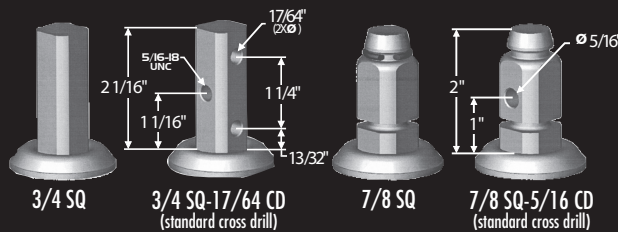

SPECIAL STEMS

***	DIAMETER	LENGTH
3/4NPT	1"	3/4"
EXP	1 1/2"	3 1/2"

